

MAXI 3

BTHEADBMSMAXI3K
BTHEADBMSMAXI3W
BTHEADBMSMAXI3B
BTHEADBMSMAXI3V

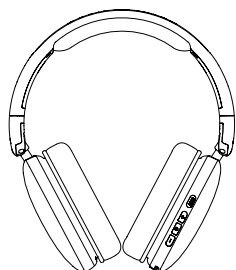

USB-C LED

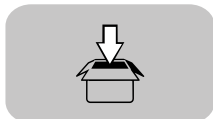
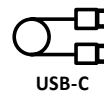
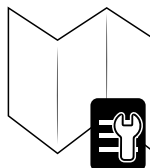

USB-C

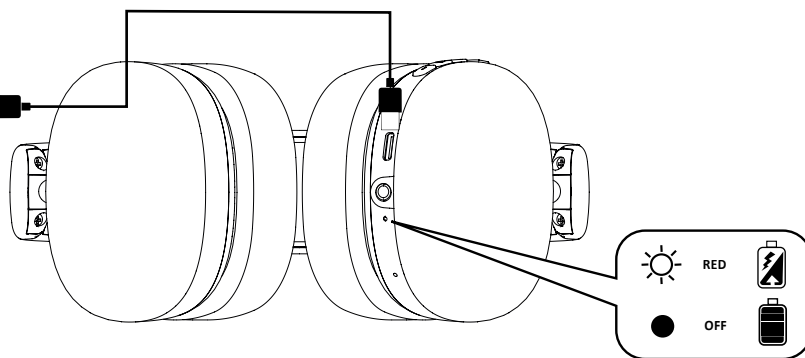
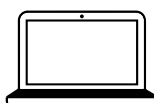

Technical specifications:
Bluetooth®: v 6
Supported profiles: Headset – Handsfree – A2DP – AVRCP
Range: 10m
Bluetooth® Frequency Range: 2402MHz-2480MHz
Battery Voltage: 3.7V
Battery Capacity: 200mAh
USB-C port Voltage (V): 5V
USB-C Port Current (A): 0,16A
ERP: +4dBm
Talk Time: approx. 13 hours
Play Time: approx. 27 hours
Charging the headphones: About 2,5 hours
Weight: 215g

Specifiche tecniche:
Bluetooth®: v 6
Profili supportati: Headset – Handsfree – A2DP – AVRCP
Portata: 10mt
Bluetooth® Frequency Range: 2.402GHz-2.480GHz
Battery Voltage: 3.7V
Battery Capacity: 200mAh
USB-C port Voltage (V): 5V
USB-C port current (A): 0.16A
ERP: +4 dBm
Talk Time: 13 ore circa
Play Time: 27 ore circa
Ricarica auricolari: 2,5 ore circa
Peso: 215 g

Spécifications techniques:
Bluetooth®: version 6
Profils supportés: Casque – Mains libres – A2DP – AVRCP
Portée: 10 m
Gamme de fréquences Bluetooth®: 2 402 MHz - 2 480 MHz
Tension de la batterie: 3,7 V
Capacité de la batterie: 200mAh
Tension du port USB-C (V): 5 V
Courant du port USB-C (A): 0,16 A
PAR: +4 dBm
Autonomie en conversation: 13 heures environ
Autonomie en lecture: 27 heures environ
Charge du casque: 2,5 heures environ
Poids: 215 g

Technische Eigenschaften:
Bluetooth®: v 6
Unterstützte Profile: Headset – Handsfree – A2DP – AVRCP
Reichweite: 10 m
Bluetooth®-Frequenzbereich: 2402 MHz-2480 MHz
Akkuspannung: 3,7 V
Akkukapazität: 200mAh
USB-C-Buchse Spannung (V): 5 V
USB-C-Buchse Strom (A): 0,16A
ERP: +4 dBm
Sprechzeit: ca. 13 Stunden
Musikwiedergabezeit: ca. 27Stunden
Aufladen des Headsets: etwa 2,5 Stunden
Gewicht: 215 g

Especificaciones técnicas:
Bluetooth®: v 6
Perfiles admitidos: Headset – Handsfree – A2DP – AVRCP
Alcance: 10 m
Rango de frecuencia Bluetooth®: 2402 MHz - 2480 MHz
Voltaje de la batería: 3,7 V
Capacidad de la batería: 200mAh
Voltaje (V) del puerto USB-C: 5 V
Corriente (A) del puerto USB-C: 0,16 A
ERP: +4 dBm
Tiempo de conversación: 13 horas aprox.
Tiempo de reproducción: 27 horas aprox.
Carga de los cascos: 2,5 horas aprox.
Peso: 215 g

Teknik özellikler:
Bluetooth®: v 6
Desteklenen profiller: Kulaklık – Eller Serbest – A2DP – AVRCP
Kapsama alanı: 10m
Bluetooth® Frekans Aralığı: 2402MHz-2480MHz
Pil Voltajı: 3.7V
Pil Kapasitesi: 200mAh
USB-C port Gerilimi (V): 5V
USB-C port akımı (A): 0.16A
ERP: +4dBm
Konuşma Süresi: Yaklaşık 13 saat
Çalma Süresi: Yaklaşık 27 saat
Kulak üstü büyük kulaklıkların yeniden sarj edilmesi: Yaklaşık 2,5saat
Ağırlık: 215g

Technische gegevens:
Bluetooth®: v 6
Ondersteunde profielen: Koptelefoon – Handsfree – A2DP – AVRCP
Bereik: 10 m
Frequentiebereik Bluetooth®: 2402MHz-2480MHz
Batterijspanning: 3,7V
Batterijcapaciteit: 200mAh
Spanning USB-C-poort (V): 5V
Stroomsterkte USB-C-poort (A): 0,16A
ERP: +4dBm
Tijdsduur in gesprek: ongeveer 13 uur
Afspeeltijd: ongeveer 27 uur
Opladetijs koptelefoon: ongeveer 2,5 uur
Gewicht: 215 g

Kuulokkeen tekniset:
Bluetooth®: v 6
Tuetut profiilit: Headset – Handsfree – A2DP – AVRCP
Kantama: 10 m
Bluetooth® taajuusalue: 2402MHz-2480MHz
Akkujännite: 3,7 V
Akun kapasiteetti: 200mAh
USB-C-portin jännite (V): 5 V
USB-C-portin virta (A): 0,16 A
ERP: +4dBm
Puhe aika: noin 13 tuntia
Musikinkuuntelu aika: noin 27 tuntia
Kuulokkeiden lataaminen: noin 2,5 tuntia
Paino: 215 g

Techniska specifikationer:
Bluetooth®: v 6
Profiler som stöds: Headset – Handsfree – A2DP – AVRCP
Räckvidd: 10 m
Bluetooth® frekvensområde: 2402MHz-2480MHz
Batterispanning: 3,7V
Batterikapacitet: 200mAh
USB-C-portens spänning (V): 5V
USB-C-port ström (A): 0,16A
ERP: +4dBm
Taltid: Cirka 13 timmar
Speltid: Cirka 27 timmar
Laddning av hörlurarna: Ca. 2,5 timmar
Vikt: 215g

Techniske specifikationer:
Bluetooth®: v 6
Understøttede profiler: Headset – Håndfri – A2DP – AVRCP
Rekkevidde: 10 m
Bluetooth® frekvensområde: 2402 Mhz - 2480 MHz
Batterispenning: 3,7 V
Batterikapacitet: 200 mAh
USB-C-portens spænding (V): 5 V
USB-C-portens strøm (A): 0,16 A
ERP: +4dBm
Taleid: Cirka 13 timer
Afspilningstid: Cirka 27 timer
Opladning af hovedtelefoner: Cirka 2,5 timer
Vægt: 215 g

Techniske egenskaper:
Bluetooth®: v 6
Støttede profiler: Headset – Handsfree – A2DP – AVRCP
Rekkevidde: 10 m
Bluetooth®-frekvensområde: 2402 MHz-2480 MHz
Batterispenning: 3,7V
Batterikapacitet: 200 mAh
Spennning USB-C-port (V): 5V
Strømstyrke USB-C-port (A): 0,16A
ERP: +4dBm
Taleid: Cirka 13 timer
Spilletid: Cirka 27 timer
Lade hovedtelefonene: ca. 2,5 timer
Vekt: 215 g

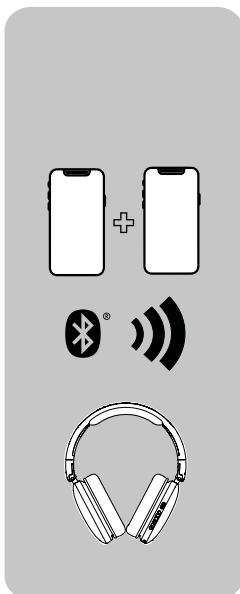
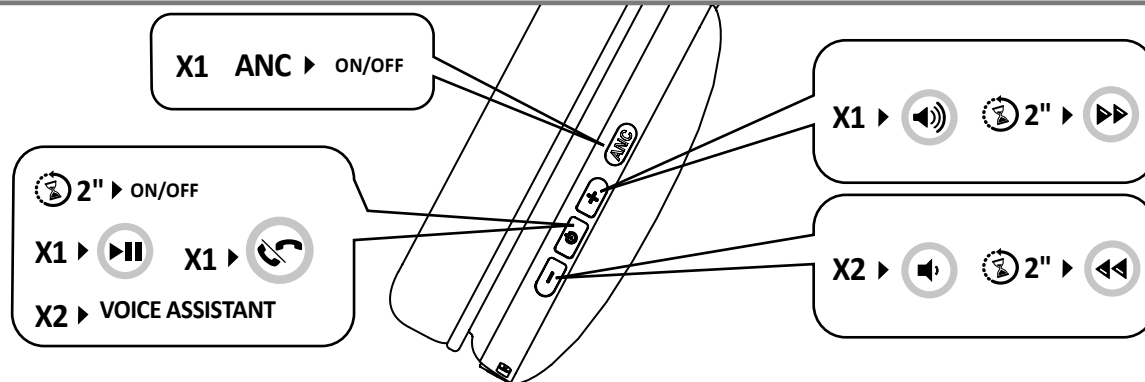
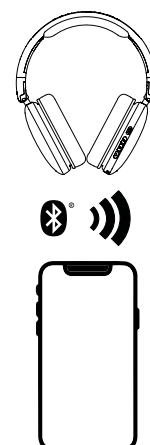
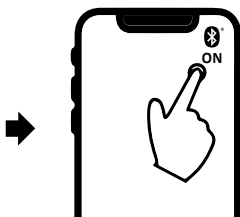
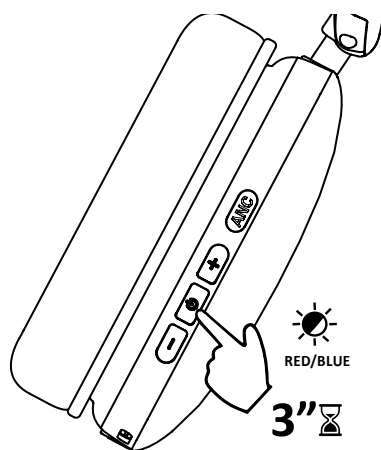

PHONE 1

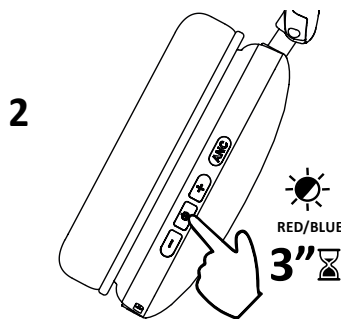
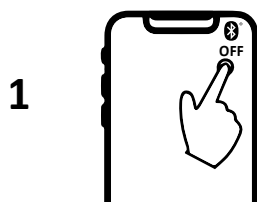

PHONE 2



PHONE 2

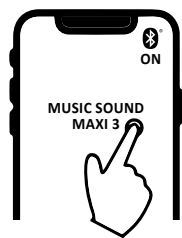

PHONE 2

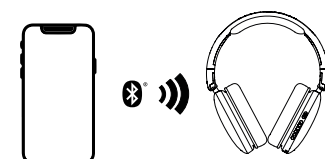

PHONE 1



PHONE 1



PHONE 1

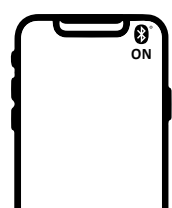

PHONE 2

